

CRANE BEAM AND BRACKET

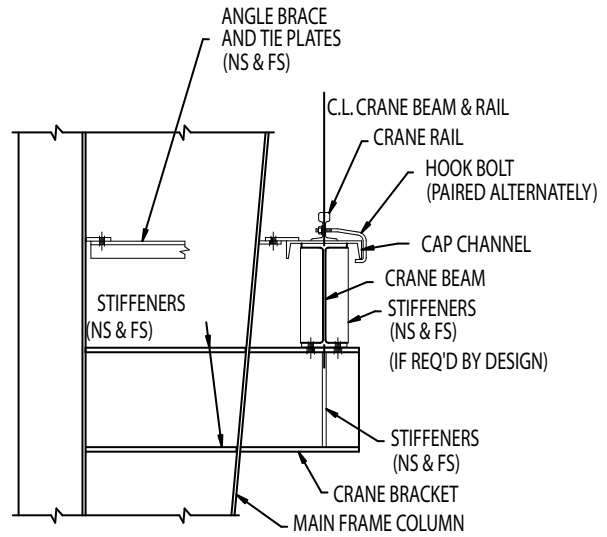

DETAIL "A"

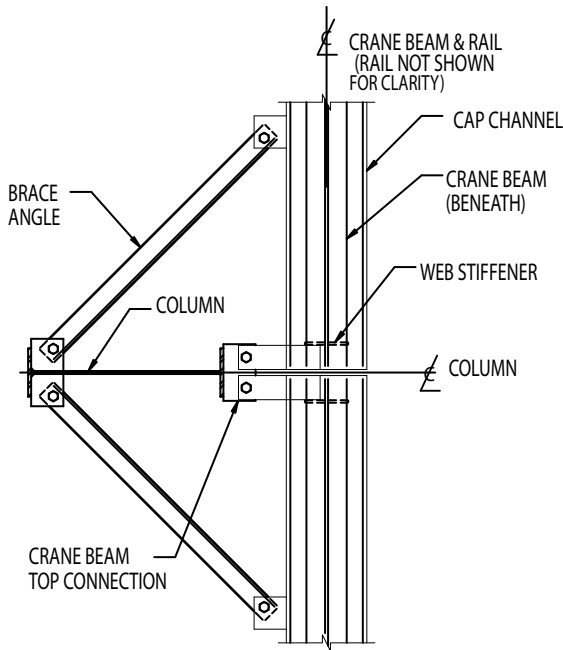

SECTION "B"

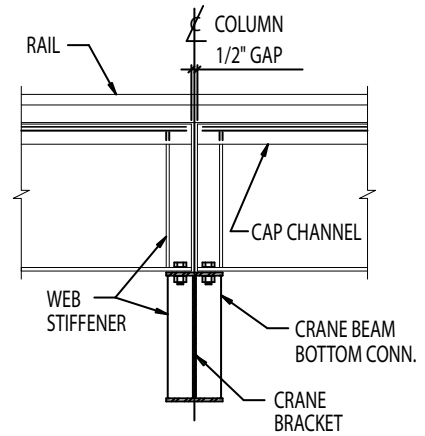

VIEW "C"

## TOP RUNNING CRANE BRACKET DETAILS

REV.	NO.	BY	CHKD.	CHKD.	NOTE: These drawings are intended to depict general installation of item(s) described above. Some item(s) may have been omitted for clarity of presentation. Consult your erection manual or additional S-Sheets for further guidelines and/or clarifications.	DRAWING NO. <b>NS46</b>
	1.0	KG		4/15/01		